



Vita Heat Pump

Operation Manual

Cooling Only System :

GWC09ATCXB-D3DNA3A/I - GWC09ATCXB-D3DNA1A/O
GWC12ATCXB-D3DNA3C/I - GWC12ATCXB-D3DNA1C/O
GWC18ATDXD-D3DNA3A/I - GWC18ATDXD-D3DNA1A/O
GWC24ATEXF-D3DNA3E/I - GWC24QEXF-D3DNC4C/O

Heat Pump System (115V) :

GWH09ATCXB-A3DNA3A/I - GWH09ATCXB-A3DNA1A/O
GWH12ATCXB-A3DNA3C/I - GWH12ATCXB-A3DNA1C/O

Heat Pump System (230V) :

GWH09ATCXB-D3DNA3A/I - GWH09ATCXB-D3DNA1A/O
GWH12ATCXB-D3DNA3C/I - GWH12ATCXB-D3DNA1C/O
GWH18ATDXD-D3DNA3A/I - GWH18ATDXD-D3DNA1A/O
GWH24ATEXF-D3DNA3E/I - GWH24QEXF-D3DNC4C/O

Freematch Indoor Units :

GWH(05)ATA-D3DNA3A/I
GWH(07)ATA-D3DNA3A/I

IMPORTANT : Please read this manual carefully before running this unit, and save it for future reference.

FOREWORD

Thank you for your purchase! This manual is the universal version for this product manufactured by GREE Canada. The appearance of the unit that you have purchased may differ from the one shown in this manual, however it does not change the basic guidelines on how to properly operate this appliance.

To ensure satisfactory operation for many years, this manual should be read carefully before using the appliance.

After reading, keep it in a safe place. Please refer to the manual if you have any questions about operation or if you encounter any irregularities that need to be corrected.

TABLE OF CONTENTS

1. SAFETY GUIDELINES

Safety Symbols Description	4
Exception Clauses	4
Compliance Statements	5
Operations and Maintenance Safety Instructions	6

2. COMPONENT SUMMARY

Indoor Unit.....	7
Outdoor Unit.....	7

3. OPERATION GUIDE

Remote Control Buttons.....	8
Remote Control Display Screen Indicators	9
Basic Operating Instructions	10
Function Description and Setting	11

4. MAINTENANCE

Cleaning the Surface.....	20
Cleaning the Dust Filter.....	20
Pre and Post Season Maintenance.....	21
Recycling and Disposal.....	21

5. TROUBLESHOOTING

Error Codes Identification.....	22
Common Malfunctions and Possible Fixes	22

6. WARRANTY..... 24



Electrical products should be properly disposed.
Please recycle where facilities exist.
Check with your local authority or retailer for recycling.

SAFETY GUIDELINES

■ SAFETY SYMBOLS DESCRIPTION

The following symbols are used throughout this manual to indicate immediate or potential hazards. It is the owner's responsibility to read and follow all safety information and instructions accompanying these symbols. Failure to heed safety information increases the risk of serious injury or death, property damage and/or product damage.

⚠ DANGER

This symbol indicates an imminently hazardous situation that, if not avoided, will cause severe personal injury, death, or substantial property damage.

⚠ WARNING

This symbol indicates a potentially hazardous situation that, if not avoided, can cause severe personal injury, death, or substantial property damage.

⚠ CAUTION

This symbol indicates a potentially hazardous situation that, if not avoided, will or can cause minor personal injury or property damage.

❗ NOTE

This symbol indicates that the items must be observed. Incorrect use may result in personal injury or property damage.

■ EXCEPTION CLAUSES

The manufacturer will not assume any liability when personal injury or property damage is caused by the following reasons:

1. Damage the product due to improper use or misuse of the product.
2. Modify, change, maintain or use the product with other equipment without complying with the manufacturer's instruction manual.
3. After verification, the product defect is directly caused by corrosive gas.
4. After verification, the defects are caused by mishandling during product transportation.
5. Operation, repair, maintenance of the unit without complying with the instruction manual or related regulations.
6. After verification, the problem or dispute is caused by the quality specifications or performance of parts and components produced by other manufacturers.
7. The damage is caused by natural disasters, bad operating environment or force majeure.

If it is necessary to install, move or service the heat pump, please contact your dealer or local service center first. The appliance must be installed, moved or serviced by qualified technicians. Failure to do so may result in serious damage or personal injury, or even death.

When refrigerant leaks or must be discharged during installation, maintenance or disassembly, it must be handled by certified professionals or in accordance with local laws and regulations.

This appliance is not intended for use by persons (including children) with reduced physical, sensory or mental capabilities or lack of experience and knowledge, unless they are given supervision or instruction in its use by a person responsible for their safety.

Children should be supervised to ensure that they do not play with the unit.

SAFETY GUIDELINES

■ COMPLIANCE STATEMENTS

WARNING: GREE Canada has not approved any changes or modifications to this device by the user. Any changes or modifications could void the user's authority to operate the equipment.

FEDERAL COMMUNICATIONS COMMISSION (FCC) REGULATIONS

This device complies with part 15 of the FCC Rules. Operation is subject to the following two conditions: (1) this device may not cause harmful interference, and (2) this device must accept any interference received, including interference that may cause undesired operation.

NOTE: This equipment has been tested and found to comply with the limits for a Class B digital device, pursuant to part 15 of the FCC Rules. These limits are designed to provide reasonable protection against harmful interference in a residential installation. This equipment generates, uses, and can radiate radio frequency energy and, if not installed and used in accordance with the instructions, may cause harmful interference to radio communications. However, there is no guarantee that interference will not occur in a particular installation.

If this equipment does cause harmful interference to radio or television reception, which can be determined by turning the equipment off and on, the user is encouraged to try to correct the interference by one or more of the following measures:

- Reorient or relocate the receiving antenna;
- Increase the separation between the equipment and receiver;
- Connect the equipment into an outlet on a circuit different from that to which the receiver is connected;
- Consult the dealer or an experienced radio/TV technician for help.

INDUSTRY CANADA (IC) REGULATIONS

This device complies with Industry Canada licence-exempt RSS standard(s). Operation is subject to the following two conditions: (1) this device may not cause interference, and (2) this device must accept any interference, including interference that may cause undesired operation of the device.

This equipment complies with FCC's and IC's RF radiation exposure limits set forth for an uncontrolled environment. The antenna(s) used for this transmitter must be installed and operated to provide a separation distance of at least 20 cm from all persons and must not be collocated or operating in conjunction with any other antenna or transmitter. Installers must ensure that 20 cm separation distance will be maintained between the device (excluding its handset) and users.

SAFETY GUIDELINES

■ OPERATION AND MAINTENANCE SAFETY INSTRUCTIONS

⚠ CAUTION:

- This appliance is not intended for use by persons (including children) with reduced physical, sensory or mental capabilities or lack of experience and knowledge, unless they are given supervision or instruction in its use by a person responsible for their safety.
- Children should be supervised to ensure that they do not play with the unit.
- Cleaning and maintenance should not be performed by unsupervised children.
- If the power cord is damaged, it must be replaced by the manufacturer, its service agent or similarly qualified persons to avoid any hazard.
- Do not plug the heat pump into a multipurpose outlet. Doing so may lead to a fire hazard.
- Disconnect the power supply when cleaning the heat pump. Failure to do so may result in electric shock.
- Do not wash the heat pump with water to avoid the risk of electric shock.
- Do not spray water on the indoor unit. This could cause electric shock or malfunction.
- Do not repair the heat pump yourself. You may expose yourself to electric shock or damage the equipment. Please contact your local dealer when you need to repair the appliance.
- When removing the dust filter, avoid touching the fins to prevent injury.
- Do not extend fingers or objects into the air inlet or outlet. Doing so could cause injury or damage.
- Do not spill water on the remote control, otherwise it could become inoperative.
- When cleaning the dust filter, do not use an open flame or hair dryer to dry the filter to avoid deformation and fire hazard.
- Do not block the air outlet or inlet. Doing so may result in malfunction.
- Do not stand or step on the outdoor unit casing, or place heavy objects on it. This could cause damage or personal injury.
- When any of the following conditions occur, turn off the heat pump and disconnect the power supply immediately, then contact your local dealer or service center for repairs.
 1. The power cord is overheating or damaged.
 2. There is abnormal sounds during operation.
 3. The circuit breaker trips frequently.
 4. The indoor unit gives off a burning smell.
 5. The indoor unit is leaking.

COMPONENT SUMMARY

INDOOR UNIT

1	Front panel
2	Upper airflow deflector
3	Lower airflow deflector
4	Air outlet
5	Air inlet
6	Display (see below)
7	Dust filter
8	Directional louvers (inside)
9	Emergency button

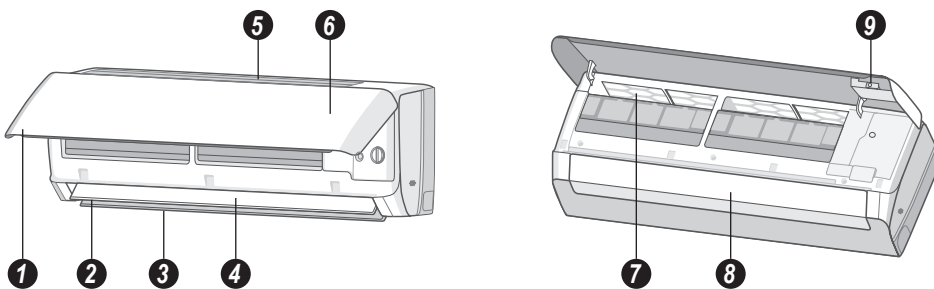

Front Panel Display

11	Temperature indicator
12	Power indicator

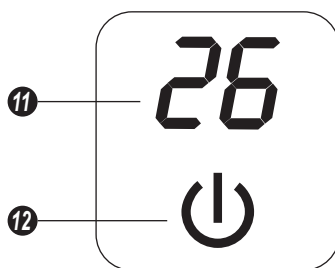

NOTE: The content of the display and the colours and shapes of the indicators may vary. Please refer to the actual display.

OUTDOOR UNIT

13	Air inlet
14	Air outlet
15	Wiring cover
16	Valve cover
17	Gas valve
18	Liquid valve

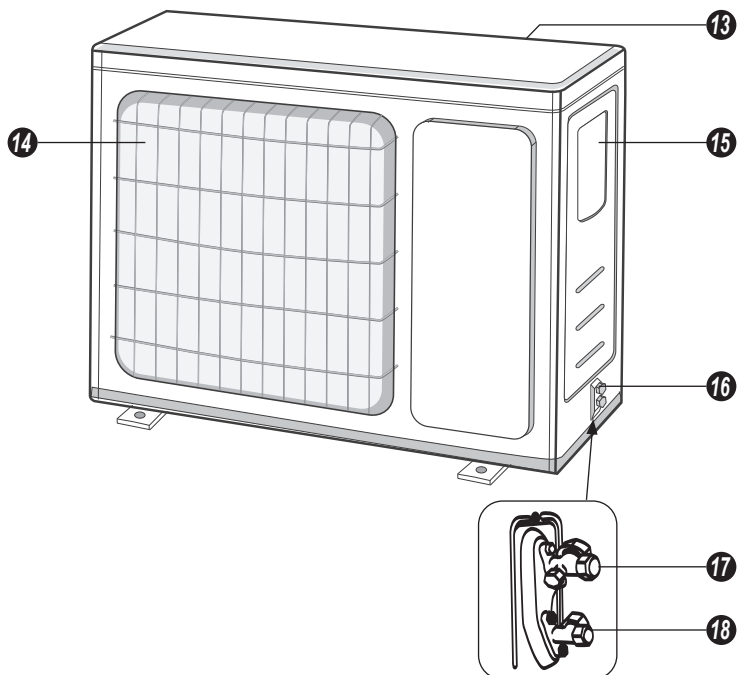

NOTE: The above illustrations are only intended to be simplified representations of the appliance and may not reflect the exact appearance of the product purchased.

OPERATION GUIDE

REMOTE CONTROL BUTTONS

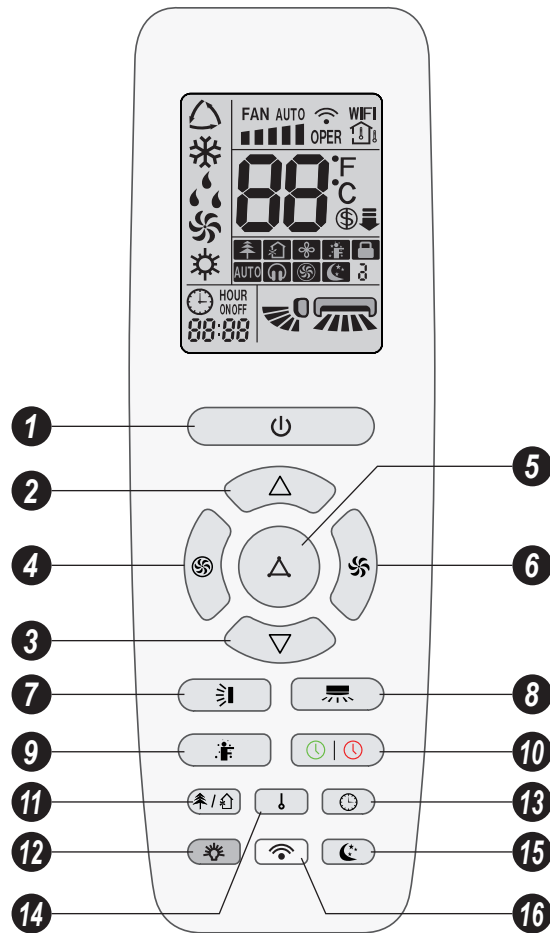

1	POWER	Turns the unit ON or OFF
2	△	Increases temperature or timer delay
3	▽	Decreases temperature or timer delay
4	TURBO	Activates or deactivates <i>Turbo</i> mode
5	MODE	Allows to select an operation modes
6	FAN	Allows to select a ventilation speed
7	VERTICAL SWING	Adjusts vertical swing angle
8	HORIZONTAL SWING	Adjusts horizontal swing angle

9	I FEEL	Activates or deactivates <i>I Feel</i> function
10	TIMER-ON / TIMER-OFF	Allows to set a switch-on or switch-on timer
11	HEALTH / SCAVENGING	Activates or deactivates <i>Health</i> and/or <i>Scavenging</i> modes
12	LIGHT	Activates or deactivates indoor unit display
13	CLOCK	Allows to set the system clock
14	TEMP	Allows to set the temperature display type
15	SLEEP	Allows to select a <i>Sleep</i> mode option
16	WIFI	Activates or deactivates <i>WiFi</i> function

❗ **NOTE:** Buttons and indicators may differ from model to model, but their functionality remains the same. Some functions may not be available on all models.

OPERATION GUIDE

REMOTE CONTROL DISPLAY SCREEN INDICATORS



	<i>I Feel</i> function	
	Set fan speed	
	<i>Turbo</i> mode	
	Sending signal	
Operation Modes		<i>Auto</i> mode
		<i>Cooling</i> mode
		<i>Drying</i> mode
		<i>Ventilation</i> mode
		<i>Heating</i> mode
	<i>Sleep</i> mode	
	8 °C <i>Heating</i> function	
	<i>Power Limit</i> mode	
	<i>Health</i> mode	

	<i>Scavenging</i> mode	
	<i>X-Fan</i> function	
Temp. display type		Set temperature
		Indoor ambient temperature
		Outdoor ambient temperature
	Clock	
	Temperature display	
	<i>WiFi</i> function	
	Time display	
	Timer-ON / Timer-OFF	
	Horizontal swing angle	
	Vertical swing angle	
	<i>Control lock</i> function	
	<i>Quiet</i> mode	

OPERATION GUIDE

BASIC OPERATING INSTRUCTIONS

BATTERY REPLACEMENT

1. Remove the battery compartment cover from the back of the remote control by lifting it in the direction of the arrow.
2. Take out the depleted batteries.
3. Insert two new 7# AAA (1.5V) dry batteries, making sure to match the polarity markings (+ and -) shown on the remote control.
4. Replace the compartment cover by sliding it into place.

NOTES:

- Do not use rechargeable batteries.
- Replace with new batteries of the same brand when replacement is required.
- Do not dispose of used batteries with other domestic waste. Separate collection of such waste for special treatment is necessary.

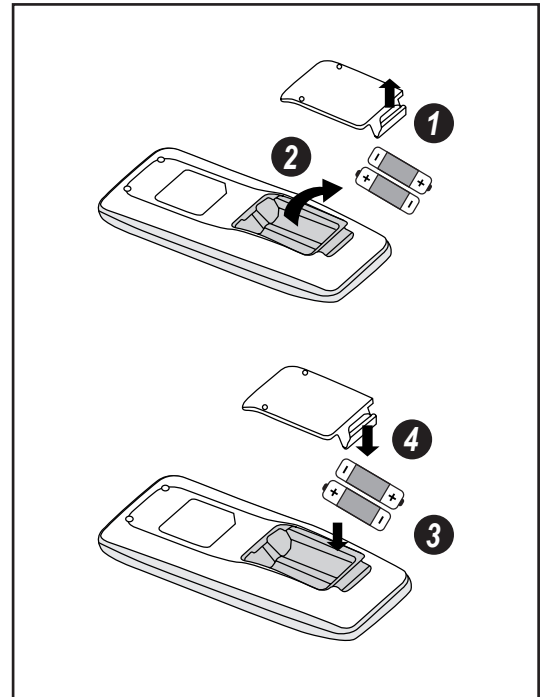

USAGE RECOMMENDATIONS

- Direct the remote control toward the signal receiver of the indoor unit for optimal use.
- In order for the signal to be transmitted successfully, the distance between the remote control and the indoor unit must be less than 8 meters (26 feet) and within a 60° angle.
- Make sure that there are no objects between the remote control and the signal receiver of the indoor unit that could block the signal.
- Never leave the remote control exposed to the sun.
- Keep the remote control at a distance greater than 1 meter (3 feet) from appliances or devices such as televisions, fluorescent lamps, wireless phones or other electrical appliances to avoid signal interference.
- When not using the remote control for an extended period of time, please remove the batteries so as not to wear them out needlessly.
- A blurry or blank display screen on the remote control may indicate a low battery level. In such a case, replace the batteries with new ones.
- If the remote control is lost or damaged, use the emergency button to turn the indoor unit on or off.

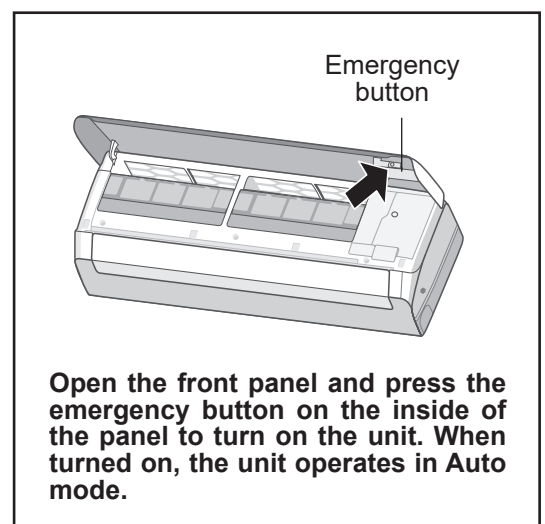
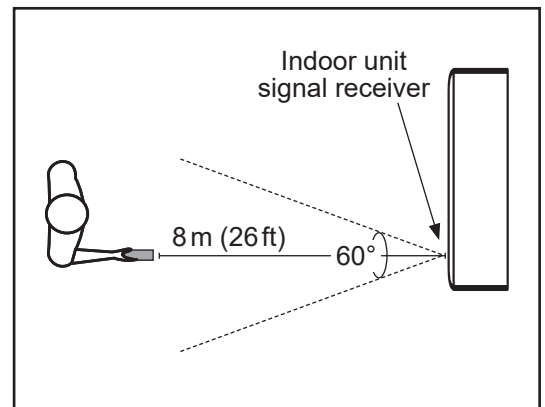

OPERATION GUIDE

FUNCTION DESCRIPTION AND SETTING

- This remote control is for general use. It can be used for multi-function heat pumps and air conditioners. For the functions that the model does not have, if you press the corresponding button on the remote control, the unit will keep its initial operating status.
- Immediately after the power is turned on, the indoor unit will make a beep and the power indicator "⏻" will light up on the indoor unit display. After this point, you can operate the heat pump using the remote control.
- In operating state, when a button on the remote control is pressed, the signal symbol "📶" on the display screen of the remote control will blink once and the indoor unit will emit a beep. This indicates the signal has been successfully received by the unit.
- Models with WiFi control or a wired thermostat must first be controlled by a standard remote in *Auto* mode. Following this, the setting of the temperature can be made via the WiFi mobile App or the wired thermostat.
- This remote control can set the temperature in *Auto* mode. When used with a unit that does not have the *Auto* mode temperature setting function, the temperature set in this mode will be invalid, or the set temperature displayed on the unit will not be the same as that on the remote control.

POWER ON/OFF

Allows the user to power the unit on or off.

Press the **POWER** button (⏻) to turn on the unit. Press again to turn off the unit.

OPERATION MODE SETTING

Allows the user to select an operation mode in accordance with their needs.

Press the **MODE** button (⏏) on the remote control to select the desired operation mode. With each press of the button, the setting options cycle through in the following order:

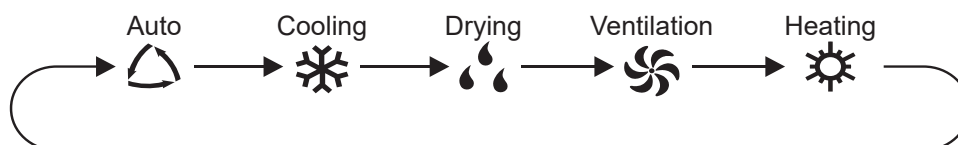

Auto Mode: In this operation mode, the unit will automatically use the best presets based on the ambient room temperature.

NOTE: Under this mode, the temperature can be displayed on the indoor unit and the set temperature can be adjusted. Use the arrow buttons (▲ or ▼) to adjust the temperature to the desired setting.

Cooling Mode: In this operation mode, the unit will cool the room to the desired temperature as well as remove moisture from the air.

Drying Mode: In this operation mode, the unit will reduce the humidity in the air to make the room more comfortable. Fan speed is automatically set to *Low* speed and cannot be adjusted.

OPERATION GUIDE

Ventilation Mode: In this operation mode, the unit will blow uncooled/unheated air. Set temperature cannot be adjusted.

Heating Mode: In this operation mode, the unit will heat the room to the desired temperature.

NOTE: To prevent cold air from being blown into the room as *Heating* mode is started, the indoor unit will delay blowing air for 1 to 5 minutes in order to preheat the air (the actual delay time depends on indoor ambient temperature).

TEMPERATURE SETTING

Allows the user to set the temperature in accordance with their needs.

Use the arrow buttons (▲ or ▼) to increase or decrease the set temperature. Each press of either button increases or decreases the value by 1 °C (or 1 °F) to a maximum of 30 °C (or 86 °F) and to a minimum of 16 °C (or 61 °F). Holding either button down for more than 2 seconds will cause the degrees to scroll up or down more quickly. Once the temperature setting is complete, the temperature indicator on the indoor unit will adjust to reflect the change.

FAN SPEED SETTING

Allows the user to select a fan speed in accordance with their needs.

Press the **FAN** button (🌀) on the remote control to select the desired fan speed. With each press of the button, the setting options cycle through in the following order:



X-FAN FUNCTION

Allows the fan of the indoor unit will blow air to eliminate moisture on the evaporator to avoid mould formation.

While in *Cooling* or *Drying* mode, hold down the **FAN** button (🌀) for at least 2 seconds to activate the *X-Fan* function. The symbol "🌀" will appear on the display screen of the remote control.

If the unit is powered down while *X-Fan* is still running, the indoor fan will continue operation for a few minutes in order to dry the inside of the indoor unit. Powering up the unit during this time will automatically deactivate the function.

If the unit has been left running with the *X-Fan* function activated, hold down the **FAN** button (🌀) for at least 2 seconds to deactivate it.

NOTE: This function is not available in *Auto*, *Ventilation* or *Heating* mode.

OPERATION GUIDE

TURBO MODE

Allows the indoor unit to run at super-high fan speed to cool or heat so that the ambient temperature reaches the set temperature much quicker.

While *Cooling* or *Heating* mode, press the **TURBO** button (🌀) in the remote control to activate the function. The symbol "🌀" will appear on the display screen of the remote control. Pressing the button again will deactivate the *Turbo* function.

HORIZONTAL SWING SETTING

Allows the user to adjust the louvers of the indoor unit to a fixed angle in accordance with their needs.

Press the **HORIZONTAL SWING** button (🪟) on the remote control to select the desired fixed angle. By pressing the button in rapid succession of less than 2 seconds, the setting options cycle through in the following order:

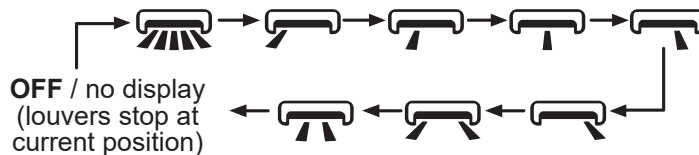

When the parameter switches from "OFF" to "🪟", if you delay pressing the button for more than 2 seconds, the parameter will automatically revert to the "OFF" state.

Holding the button down continuously for more than 2 seconds will cause the airflow deflectors and louvers to automatically swing back and forth, and sides to sides. When the button is released, the unit stops swinging at the current angle, providing the user with a personalized fixed angle.

NOTE: Some angle options are only available for certain models.

VERTICAL SWING SETTING

Allows the user to adjust the airflow deflectors of the indoor unit to a fixed angle or to continuously swing in accordance with their needs.

Press the **VERTICAL SWING** button (🪟) on the remote control to select the desired fixed or sliding angle. By pressing the button in rapid succession of less than 2 seconds, the setting options cycle through in the following order:

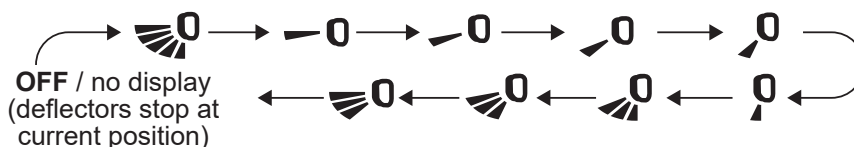

When the parameter switches from "OFF" to "🪟", if you delay pressing the button for more than 2 seconds, the parameter will automatically revert to the "OFF" state.

When selecting the parameter "🪟", the airflow deflectors will continuously swing up and down at maximum angle.

OPERATION GUIDE

Holding the button down continuously for more than 2 seconds will cause the airflow deflectors and louvers to automatically swing back and forth, and sides to sides. When the button is released, the unit stops swinging at the current angle, providing the user with a personalized fixed angle.

❗ **NOTE:** Some angle options are only available for certain models.

TIMER SETTING

SWITCH-ON TIMER

Allows the user to set a switch-on timer. The unit will switch on once the start delay has been reached.

Press the **TIMER-ON** button (🕒) on the remote control. The symbol "🕒" on the display screen of the remote control will disappear and the word "ON" will start blinking. Use the arrow buttons (▲ or ▼) to set the desired time. Each press of either button increases or decreases the time by 1 minute. Holding either button down for more than 2 seconds will cause the minutes to scroll up or down more quickly. Once completed, press the **TIMER-ON** button (🕒) to confirm the timer setting. The symbol "🕒" will reappear on the display screen and the word "ON" will stop blinking.

To cancel a switch-on timer that has been set, press the **TIMER-ON** button (🕒) on the remote control.

SWITCH-OFF TIMER

Allows the user to set a switch-off timer. The unit will stop running when the set operating time has elapsed.

Press the **TIMER-OFF** button (🕒) on the remote control. The symbol "🕒" on the display screen of the remote control will disappear and the word "OFF" will start blinking. Use the arrow buttons (▲ or ▼) to set the desired time. Each press of either button increases or decreases the time by 1 minute. Holding either button down for more than 2 seconds will cause the minutes to scroll up or down more quickly. Once completed, press the **TIMER-OFF** button (🕒) to confirm the timer setting. The symbol "🕒" will reappear on the display screen and the word "OFF" will stop blinking.

To cancel a switch-off timer that has been set, press the **TIMER-OFF** button (🕒) on the remote control.

❗ NOTES:

- A switch-on and switch-off timer can be active concurrently.
- Before setting a timer, ensure that the system clock has been set to current time.
- Once the clock is set, the heat pump will turn on or off when the delay elapsed. When the unit is under a timer setting, the **POWER** button (🔌) will have no effect on operation. If the timer is no longer needed, use the remote control to cancel it.
- During timer setting, if no operation is performed for 5 seconds, the setting is canceled.

I FEEL FUNCTION

Allows the user to use the remote control as the primary temperature sensor in order for the indoor unit to provide better comfort based on the location of the user and remote control.

Press the **I FEEL** button (👤) on the remote control to activate the function. The symbol "👤" will appear

OPERATION GUIDE

on the display screen of the remote control. Once activated, the remote control will transmit the ambient temperature measured at its location to the indoor unit and the unit will automatically adjust its operation in accordance to the transmitted temperature. Pressing the button again will deactivate the *I Feel* function.

Once activated, the user should keep the remote control in close proximity for the function to be effective. The remote control should also be kept within an area where the indoor unit can receive its signal. Do not place the remote control near high temperature appliances or devices to avoid measuring an inaccurate ambient temperature.

CLOCK SETTING

Allows the user to set the system clock to current time.

Press the **CLOCK** button (🕒) on the remote control to set the time. The symbol "🕒" will start blinking on the display screen of the remote control. Use the arrow buttons (▲ or ▼) to set the time. Each press of either button increases or decreases the time by 1 minute. Holding either button down for more than 2 seconds will cause the minutes to scroll up or down more quickly. Once the clock setting is complete, press the **CLOCK** button (🕒) to confirm. The symbol "🕒" will stop blinking.

NOTES:

- Clock time adopts the 24-hour time format.
- If no operation is performed for 5 seconds, the setting is canceled.

SLEEP MODE

Allows the user to select a preset sleep curve or create a customized one in accordance with their needs.

Press the **SLEEP** button (🌙) on the remote control to select the desired sleep curve. With each press of the button, the setting options cycle through in the following order:



Sleep 1: In *Cooling* mode, one hour after the mode is set, the temperature increases by 1°C. After two hours, the temperature increases by another 2°C. The unit then holds this temperature.

In *Heating* mode, one hour after the mode is set, the temperature decreases by 1°C. After two hours, the temperature decreases by another 2°C. The unit then holds this temperature.

Sleep 2: In this mode, the unit operates according to a group of sleep temperature curve presets.

Sleep 3: In this mode, the user can create their own custom sleep curve by following the procedure below.

1. Hold down the **TURBO** button (⚡) for some time until the remote control enters user customization status. The remote control time display will show "1:00" and the temperature display will show the corresponding temperature of the last sleep curve setting and will blink (on the very first input, the displayed temperature will be in accordance with the factory's initial curve setting).

2. Use the arrow buttons (▲ or ▼) if you wish to change the corresponding temperature setting.

OPERATION GUIDE

Once completed, press the **TURBO** button (⌚) to confirm the setting.

3. Following confirmation, the time displayed on the remote control screen will automatically increase by 1 hour (going from "1:00" to "2:00", then "3:00", and so on up to "8:00") and the temperature display will blink, as previously.

4. Repeat the above steps 2 and 3 until the temperature is set for all 8 hours of the sleep curve. Once the sleep curve setting is completed, the time and temperature display on the remote control will return to its original display.

The user can view or revise a custom sleep curve. Hold down the **TURBO** button (⌚) for some time until the remote control enters user customization status. To view the setting without change, simply press the **TURBO** button (⌚) to move on to the next setting. If a setting needs to be adjusted, Use the arrow buttons(▲ or ▼) to do so then press the **TURBO** button (⌚) to confirm the new setting.

NOTES:

- While setting a custom sleep curve, if no operation is performed for more than 10 seconds, the process will be automatically cancelled and the time and temperature display on the remote control will return to its original display.
- While setting a custom sleep curve, pressing the **POWER** (⏻), **MODE** (▲) or **SLEEP** (☾) button will automatically cancel the process.

WIFI FUNCTION

Allows the user to control the unit remotely from their smartphone or tablet using the GREE+ App.

Press the **WIFI** button (📶) on the remote control to activate the function. The word "WiFi" will appear on the display screen of the remote control. Holding down the **WIFI** button (📶) for at least 5 seconds will deactivate the WiFi function.

Holding down the **MODE** (▲) and **WIFI** (📶) buttons simultaneously for 1 second will restore the WiFi module to factory settings.

NOTE: This function is only available for some models.

HEALTH AND SCAVENGING MODES

Allows the unit to clean the air by removing dust particles and germs and/or to gradually replace stale air inside the room with fresh outside air.

Press the **HEALTH / SCAVENGING** button (🌿 / 🏠) on the remote control to select the desired mode(s). With each press of the button, the setting options cycle through in the following order:

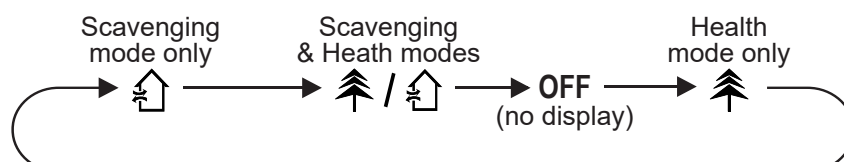

OPERATION GUIDE

INDOOR UNIT DISPLAY SETTING

Allows the indoor unit to display of the temperature and power indicators on its front panel.

Press the **LIGHT** button (☼) on the remote control to turn on the display of the indoor unit's front panel. Press the button again to turn off the display.

TEMPERATURE DISPLAY SETTING

Allows the user to select the type of temperature displayed on the indoor unit's front panel.

Press the **TEMP** button (↓) on the remote control to set the temperature type to *set temperature*. The symbol "⏴" (or no display, depending on model) will appear on the display screen of the remote control. Press the button again to set the temperature type to *indoor ambient temperature*. The symbol "⏵" will appear on the display screen.

ENERGY-SAVING FUNCTION

Allows the indoor unit to automatically adjust the set temperature based on factory setting to achieve the best energy saving performance.

While in *Cooling* mode, press the **TEMP** (↓) and **CLOCK** (⌚) buttons simultaneously on the remote control to activate the function. The temperature display of the remote control will show "SE". Press the same buttons simultaneously again to deactivate the *Energy-Saving* function.

❗ NOTES:

- When *Energy-Saving* is active, the set temperature cannot be adjusted and the fan speed is automatically set to *Auto* speed and cannot be changed. Pressing the **TURBO** button (⚡) will result in no signal being sent.
- The *Sleep* and *Energy-Saving* functions cannot operate concurrently. If *Energy-Saving* has been previously set, activating *Sleep* mode will automatically cancel the *Energy-Saving* function. Conversely, if a *Sleep* mode has been previously set, activating the *Energy-Saving* function will automatically cancel the *Sleep* function.

8°C HEATING FUNCTION

Allows the indoor unit to automatically start heating operation to maintain an indoor ambient temperature of 8°C (46°F) to prevent property damage when the user is absent for an extended period of time.

While in *Heating* mode, press the **TEMP** (↓) and **CLOCK** (⌚) buttons simultaneously on the remote control to activate the function. The symbol "Ⓢ" will appear on the display screen of the remote control and the temperature indicator will show "8°C". Press the same buttons simultaneously again to deactivate the 8°C *Heating* function.

❗ NOTES:

- When 8°C *Heating* is active, the set temperature cannot be adjusted and the fan speed is automatically set to *Auto* speed and cannot be changed. Pressing the **TURBO** button (⚡) will result in no

OPERATION GUIDE

signal being sent.

- The *Sleep* and *8 °C Heating* functions cannot operate concurrently. If *8 °C Heating* has been previously activated, activating *Sleep* mode will automatically cancel the *8 °C Heating* function. Conversely, if a *Sleep* mode has been previously set, activating the *8 °C Heating* function will automatically cancel the *Sleep* function.
- If the temperature measuring unit has been set to Fahrenheit, the temperature indicator of the remote control will show "48^F" instead of "8^{°C}".

CONTROL LOCK FUNCTION

Allows the user to lock the remote control buttons to prevent a young child or others from changing the settings.

Press the arrow buttons (▲ or ▼) simultaneously on the remote control to activate the function. The symbol "🔒" will appear on the display screen of the remote control. Once activated, the buttons of the remote control will become inoperative. Attempting to use the controls while the remote is locked will cause the symbol "🔒" to blink three times on the display screen and no signal will be sent to the unit. Press the same buttons simultaneously again to deactivate the *Control Lock* function.

TEMPERATURE MEASURING UNIT SETTING

Allows the user to select between Celsius or Fahrenheit as the temperature measuring unit for the display.

While the unit is turned off, press the **MODE** button (△) and arrow button "▼" simultaneously to select Celsius as the desired temperature measuring unit for the display. Press the same buttons simultaneously again to select Fahrenheit.

SELF-CLEANING FUNCTION

Allows the indoor unit to clean itself, removing the accumulated dirt and bacteria from the evaporator.

While the unit is turned off, hold down the **MODE** (△) and **FAN** (🌀) buttons simultaneously on the remote control for at least 5 seconds to activate the function. The temperature display of the remote control will show "🔧". Hold down the same buttons again for at least 5 seconds to cancel the *Self-Cleaning* function.

During the self-cleaning process, the unit will alternate between fast cooling and fast heating. This may create sounds of thermal expansion or shrinkage, or of flowing liquid. The unit may also blow cool or warm air, which is a normal phenomenon. Once the cleaning process is complete, the unit will go into standby mode.

❗ NOTES:

- During cleaning process, make sure the room is well ventilated so as not to affect the level of comfort.
- The *Self-Cleaning* function can only work under normal ambient temperature. If the unit is located in a dusty environment, run this function once a month; if it is not, every three months is sufficient.
- This function is only available for some models.

OPERATION GUIDE

POWER LIMIT MODE

Allows the system to limit the maximum output power.

Press the **MODE** (Δ) and **SLEEP** (☾) buttons simultaneously on the remote control to select the desired *Power Limit* mode. With each press of the buttons, the setting options cycle through in the following order:

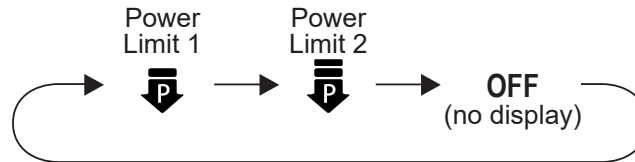

The maximum power limit of the **Power Limit 2** setting is lower than that of the **Power Limit 1** setting.

If the remote control is turned off or the battery are removed while *Power Limit* is active, the function will be automatically cancelled. Reactivate the function to resume the power limiting operation.

If the current power is lower than the maximum power of the **Power Limit 2** setting, then the power will not be limited after entering this mode.

For an installation with one outdoor unit and two indoor units, if any one of the indoor unit enters into *Power Limit* function, the outdoor unit will enter into the set limiting power mode of that indoor unit. If the two indoor units enter into *Power Limit* function, then the power of outdoor unit will be limited in accordance with the lower power of the two indoor units.

NOTE: This function is only available for some models.

MAINTENANCE

⚠ WARNING :

- Turn off the unit and unplug the power supply before cleaning to avoid electric shock.
- Do not wash the indoor unit with water to avoid electric shock.
- Do not use volatile liquid to clean the indoor unit.
- Do not use liquid or corrosive detergent to clean the indoor unit and do not splash water or other liquid on the unit, otherwise it may damage the plastic components or even cause electric shock.

■ CLEANING THE SURFACE

Gently wipe the surface of the indoor unit with a dry cloth or one moistened with warm water.

If using a damp cloth, use water no warmer than 40 °C (104 °F).

Try to clean the unit frequently to keep it in good condition.

❗ **NOTE :** Do not remove the front panel when cleaning it.

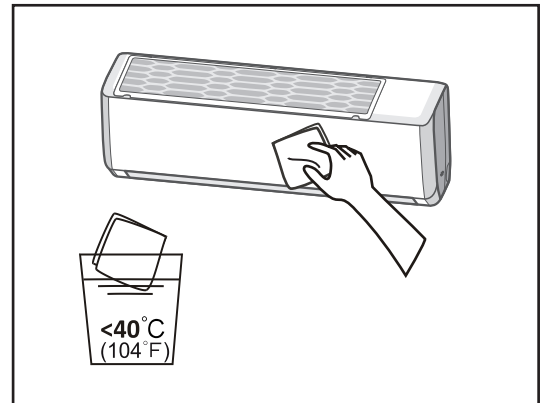

■ CLEANING THE DUST FILTER

1. To remove the filter, first press the spring fasteners at both ends in the direction indicated by the arrows in the illustration, then release the filter from the clamps. Pull the filter forward and remove it.
2. Use clean water to wash the dust filter or a vacuum to collect the dust. If the filter is very dirty (e.g. grease), use warm water (45 °C) with a neutral detergent to clean it. Put the filter in a shaded location to dry it.
3. After cleaning, reinstall the filter by sliding it along the guide rails on both sides, then press the edges of the filter to snap it into place, as indicated by the arrows in the illustration.

⚠ WARNING :

- The filter should be cleaned every three months. If there is a lot of dust in the operating environment of the indoor unit, filter cleaning should be more frequent.
- When removing the dust filter, avoid touching the fins to prevent injury.
- Do not use an open flame or hair dryer to dry the dust filter to avoid deformation and fire hazard.

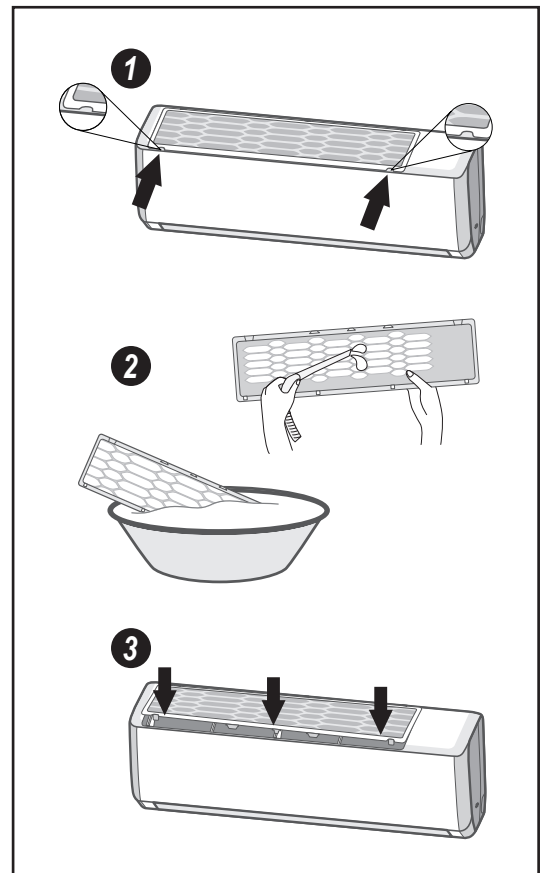

MAINTENANCE

■ PRE AND POST SEASON MAINTENANCE

PRE-SEASON

1. Clean the indoor unit and the dust filter.
2. Check for obstructions at the air inlet and outlet of the indoor and outdoor units.
3. Check that the drain pipe is not blocked or damaged.
4. Check if the mounting bracket of the outdoor unit is damaged or corroded. If so, please contact your dealer.
5. Insert batteries in the remote control and check that the unit is working properly.

POST-SEASON

1. Disconnect the power supply of the heat pump.
2. Clean the indoor unit and the dust filter.
3. Check if the mounting bracket of the outdoor unit is damaged or corroded. If so, please contact your dealer.
4. Remove the batteries from the remote control.

■ RECYCLING AND DISPOSAL

Many of the packaging materials in this product are recyclable. Please dispose of them with the recyclable waste collected by your municipality.

Unwanted electrical equipment and used batteries should not be treated as domestic waste because the items may pose environmental hazards. Electronic and electrical equipments can contain toxic substances which can produce toxic air pollutants and contaminate soil. If you wish to dispose of your equipment, please contact your local dealer, service center or local authority for the proper disposal method.

TROUBLESHOOTING

■ ERROR CODES IDENTIFICATION

If the heat pump has a faulty component, the temperature indicator on the indoor unit will flash an error code. Please refer to the list below to identify the error code and to solve the issue.

ERROR CODE	DESCRIPTION	SOLUTION
E1	System high pressure protection	These errors can be normally cleared by restarting the unit. If it does not, please contact your local dealer or service center to obtain assistance.
E5	Over-current protection	
E6	Indoor and outdoor units communication error	
E8	System high temperature protection	
H3	Compressor overheat protection	
H6	Fan motor malfunction	
C5	Jumper cap malfunction	These errors require the expertise of qualified technicians in order to be resolved. Please contact your local dealer or service center.
F0	Refrigerant shortage or blockage protection	
F1	Indoor ambient temperature sensor open or short-circuited	
F2	Evaporator temperature sensor open or short-circuited	

❗ NOTE: If you get other error codes, please contact your local dealer or service center for clarification and servicing (if necessary).

■ COMMON MALFUNCTIONS AND POSSIBLE FIXES

If your unit is performing abnormally or appears to be malfunctioning, please first review the following diagnostics before requesting service. It may be that a simple fix will solve your problem. However, if the problem persists, call **1 800 686-2175** or send an email to proservice@gree.ca for assistance.

SITUATION	POSSIBLE CAUSES	SOLUTIONS
The indoor unit does not appear to be operating.	There may have been a power outage.	If there is a power outage and the electricity is not yet restored, wait for the power to be restored. When it is, the unit may need to be restarted.
	The power cord plug may have become loose from the outlet.	Firmly push the plug into the power outlet.
	A circuit breaker may have been tripped or a fuse may have blown.	Replace the fuse or reset the circuit breaker. Make sure that there are no other appliances on the same circuit.
	There may be an active switch-on timer currently preventing operation.	If the timer setting was not intended, cancel it using the remote control, otherwise wait until the unit starts at the set time.
The compressor does not appear to be operating.	The unit may have been immediately restarted after having being shut off, or the operation mode may have been recently changed.	When changing operation modes or when immediately turning on the unit after having turned it off, a 3-minute protection delay is triggered to protect the compressor. Wait until the delay has elapsed.
The indoor unit appears to be operating abnormally.	There may be interference in the room from a television, fluorescent lamp, a wireless device, etc.	Disconnect and reconnect the power to the unit, then restart the appliance.
The indoor unit emits undesirable odours.	Odours may be caught by the indoor or outdoor unit and blown into the room with the air, or the dust filter may be dirty.	Remove any source of odours in the vicinity of both the indoor or outdoor units. Check and clean the dust filter if necessary.
The indoor unit emits cracking sounds.	The indoor unit may have been recently turned on or off.	This is a normal phenomenon. The plastic components of the indoor unit are subject to thermal expansion and contraction caused by temperature changes. No action is required.
The indoor unit emits a sound of flowing liquid.	The indoor unit may have been recently turned on or off.	This is a normal phenomenon. The refrigerant inside the indoor unit is moving due to operation starting which produces the sound of flowing liquid. No action is required.

TROUBLESHOOTING

The set temperature cannot be adjusted.	The temperature you require may exceed the setting range of the unit.	Set the temperature between a minimum of 16 °C (61 °F) to a maximum of 30 °C (86 °F).
	A function or mode currently enabled may be preventing the adjustment of the temperature.	Some functions (e.g. <i>Energy-Saving</i> , <i>8 °C Heating</i>) and operation modes (e.g. <i>Ventilation</i>) does not allow the user to adjust the set temperature. First, deactivate the function or change operation mode, then adjust the set temperature.
No airflow appears to be coming from the indoor unit.	The air inlets or outlets of the indoor or outdoor unit may be obstructed.	Clear away any objects or furniture that could be blocking the air inlet or outlet of either units.
	The indoor ambient temperature may have reached the set temperature.	When the room temperature reaches the set temperature, the indoor unit stops blowing out cooled or heated air. No action is required unless the temperature is not to your liking, in which case, adjust the set temperature.
	<i>Heating</i> mode may have just been selected as the operation mode.	To prevent cold air from being blown into the room as <i>Heating</i> mode is started, the indoor unit will delay blowing air for 1 to 5 minutes in order to preheat the air. Wait until the delay has elapsed.
The indoor unit does not respond to remote control commands.	The distance between the indoor unit and the remote control may be too great.	Get within range of the indoor unit so that the signal from the remote control can be transmitted successfully.
	The remote control may not be properly aligned with the indoor unit's signal receiver.	Make sure to be facing the unit as much as possible when pressing buttons on the remote control.
	There may be a fluorescent lamp in the room.	Turn off the fluorescent lamp and try again, or move closer to the indoor unit.
	The indoor unit may be significantly interfered by static pressure, unstable voltage, etc.	Unplug the power cord, wait for about 3 minutes, reconnect the power, then turn on the unit and try using the remote control.
	There may be objects obstructing the signal from the remote control.	Remove any possible obstructions between the remote control and the indoor unit that could be blocking the signal.
	The remote control buttons may be inoperative due to the <i>Control Lock</i> function being enabled.	Deactivate the <i>Control Lock</i> function.
	The batteries of the remote control may be depleted.	Replace the depleted batteries with new one.
The efficiency of the cooling or heating is very poor.	The dust filter may be dirty.	Check and and clean the dust filter.
	The set temperature may not be suitable for the current outdoor conditions.	Set the temperature to be higher or lower, depending in the conditions.
	The air inlets or outlets of the indoor or outdoor unit may be obstructed.	Clear away any objects or furniture that could be blocking the air inlet or outlet of either units.
	There may be heat sources present when attempting to cool the room.	Turn off or remove any heat sources that could be counteracting the cooling efficiency of the unit.
	Doors or windows may have been left open in the room.	Close doors and windows to prevent cooled or heated air from escaping the room.
The airflow deflectors do not appear to close normally.	The airflow deflectors may have been adjusted manually.	Disconnect the power for 3 seconds, then reconnect power and restart the unit. If the problem persists, disconnect the power, reinstall the airflow deflectors (first install the upper deflector, then the lower deflector), then reconnect power.

⚠ WARNING :

- When any of the following conditions occur, turn off the heat pump and disconnect the power supply immediately, then contact your local dealer or service center for repairs.
 1. The power cord is overheated or damaged.
 2. There is abnormal sounds during operation.
 3. The circuit breaker trips frequently.
 4. The air conditioner gives off a burning smell.
 5. The indoor unit is leaking.
- Do not repair the heat pump yourself. You may expose yourself to electric shock or damage the equipment.

WARRANTY

■ LIMITED WARRANTY

This product is covered by a limited warranty against manufacturing defects in materials and workmanship, if used for the applications specified in this manual, for a period of **TEN (10) years on parts and compressor** from the date of original purchase in Canada.

During the warranty period, if the appliance fails under normal use, GREE Canada will, at its option, either repair the unit or replace it, free of charge, within a reasonable period of time after the product is returned.

As a condition to any warranty service obligation, the customer must present this warranty certificate along with the proof of purchase.

■ THIS WARRANTY DOES NOT COVER...

- Damage, accidental or otherwise, to the appliance that is not caused by materials or workmanship defect.
- Damage caused by misuse, tampering or failure to follow the operating and maintenance instructions provided in this manual.
- Damage to the finish of the unit enclosure or to other outer features caused by wear.
- The filters.
- Damage caused by repairs or modifications to the appliance made by any person not duly authorized by GREE Canada.
- Insurance and freight costs for the warranty service.

ALL IMPLIED WARRANTIES, INCLUDING ANY IMPLIED WARRANTY OF MERCHANTABILITY, ARE LIMITED TO A **TEN-YEAR (10) PERIOD ON PARTS AND COMPRESSOR** COVERED BY THIS EXPRESS LIMITED WARRANTY. GREE CANADA DISCLAIMS ANY LIABILITY FOR CONSEQUENTIAL OR INCIDENTAL DAMAGES AND, IN NO EVENT SHALL GREE CANADA LIABILITY EXCEED THE RETAIL VALUE OF THE APPLIANCE FOR BREACH OF ANY WRITTEN OR IMPLIED WARRANTY WITH RESPECT TO THIS PRODUCT.

Keep this manual along with your proof of purchase in a safe place for future reference. You must provide proof of purchase for warranty service.

Enter the following information about your product; it will help you upon getting assistance or service, if you ever need it. You will have to provide the model and serial numbers of the product. These informations are detailed on the rating plate of the unit.

Dealer name: _____

Address: _____

Model number: _____

Serial number: _____

Date of purchase: _____